

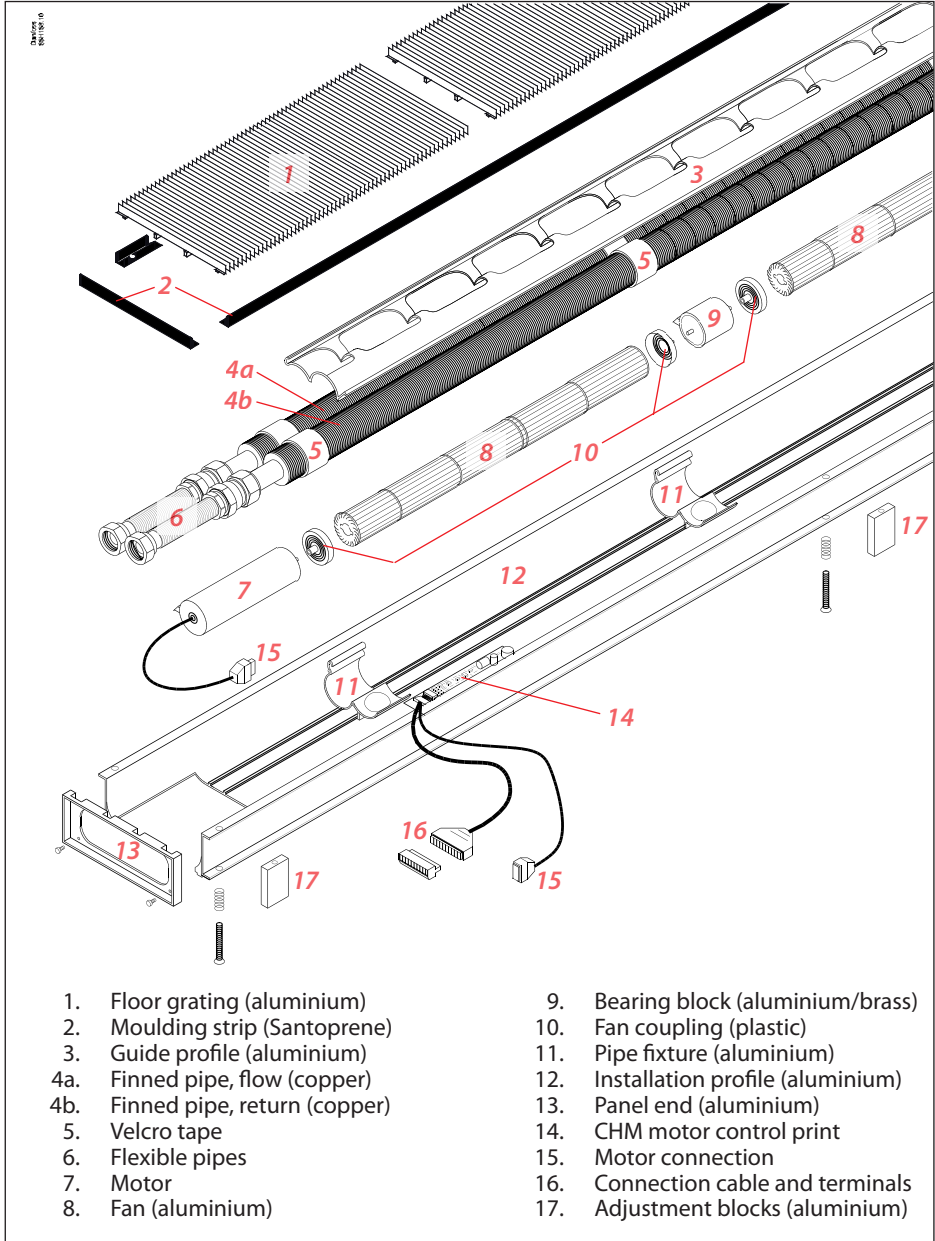

FloorLine Installation Instructions



FloorLine Panels - overview



Contents

FloorLine Panel - overview	page 2
Contents	page 3
Introduction	page 4
Unpacking the panel	page 5
Positioning of installation fittings.....	page 6
Installing the panel	page 6
Checking the joints	page 8
Power connection	page 8
Adjusting the panel	page 9
Opening the guide profile.....	page 9
Connecting several panels in series.....	page 11
Diagram: Control with TWW room thermostat	page 13
Diagram: Control via external CTS signal	page 14
Operating conditions	page 15

Introduction

Read these installation instructions carefully before installing the Convex FloorLine panel.

The installation of FloorLine panels is divided into pre-installation and final installation.

Pre-installation comprises installation of fittings and any shut-off valves connected to the heating system as well as electric wiring.

Final installation comprises the panel itself, which should be installed as late in the building process as possible to provide the best protection of mechanical parts against dust and paint residue, as well as shocks, impacts and other damage.

Installation duct

The panels are supplied with self-jointing rubber strips, which “absorb” small inaccuracies in the installation duct.

To achieve the visually best result, it is necessary to observe the measurements of the installation duct as precisely as possible, particularly the duct width of 139 mm (see page 6).

Adjustments

The FloorLine panels are equipped with integrated adjustment screws, which enable accurate adjustment of the panel height to align with the floor level.

Please ensure that all adjustment screws are resting on the base to achieve maximum stability.

Before installation

Before installation of the panel the following should be completed:

- System pipes, flow and return
- External wiring for CHR/BMS and power supply
- Check! Measurements of the installation duct and level of final floor
- Check! Panel number

NB!

All electrical and plumbing work must be carried out by authorised electricians and plumbers.

Unpacking the panel 1/3

Check the panel number on the box.

Break the seal on the box.

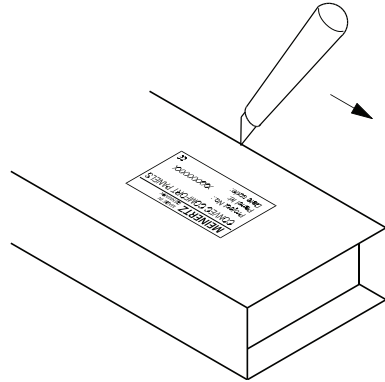

Unpacking the panel 2/3

Open the box.

Lift the gratings off the panel and place them on the opened part of the box.

NB! Avoid mixing gratings from different panels as they are cut to individual dimensions.

Remove the panel from the box.

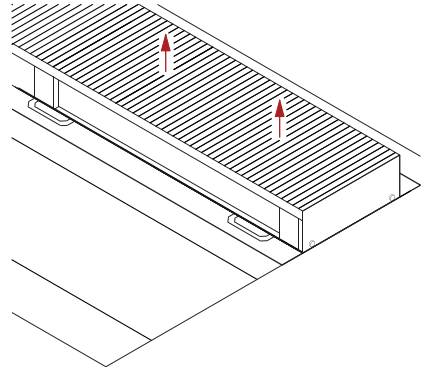

Unpacking the panel 3/3

Under the panel is a protective sheet of strong cardboard. Use this to protect the panel against dust, impacts, etc.

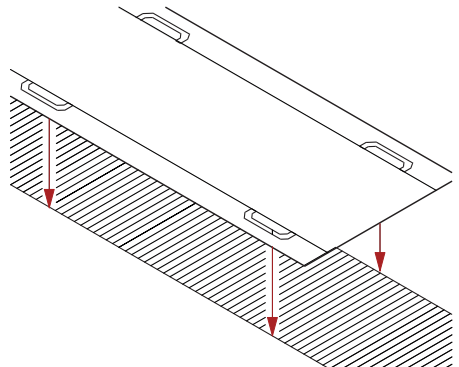

Positioning of installation fittings 1/2

Check that the installation duct meets the specified dimensions. If the duct is deeper than 73 mm, a stable support must be created for the panel.

Duct length can be calculated as follows:

- Panels **shorter** than 6000 mm: the length equals total panel length + 5 mm.
- Panels **longer** than 6000 mm: the duct is extended further 1 mm per meter panel.

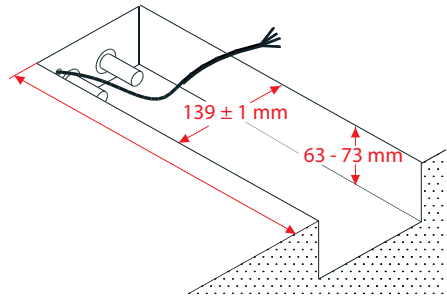

Positioning of installation fittings 2/2

Fix the enclosed installation fitting to the base of the installation duct.

Connect the system pipes.

NB! Check that the flow and return pipes are correctly positioned.

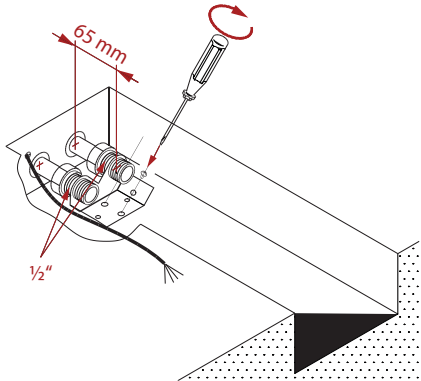

Installing the panel 1/4

1. Flow
2. Return
3. Flexible pipes
4. Terminal
5. Motor

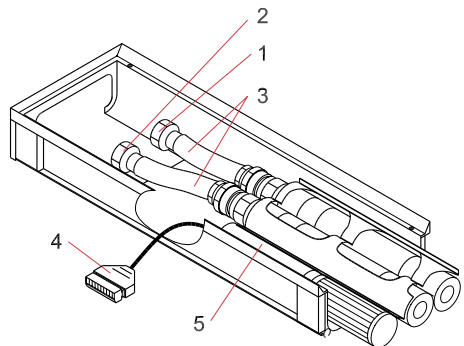

Installing the panel 2/4

Lower the FloorLine panel into the installation duct.

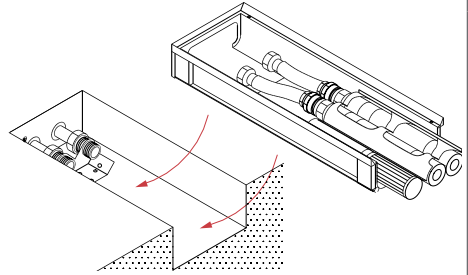

Installing the panel 3/4

Attach the flexible pipes to the installation fittings.

NB! The enclosed gaskets must be used.

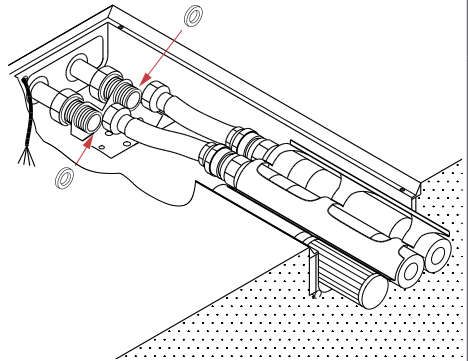

Installing the panel 4/4

Tighten the joints with a moderate torque.

You are recommended to use an NV24 open ring spanner (order no. 088H4821).

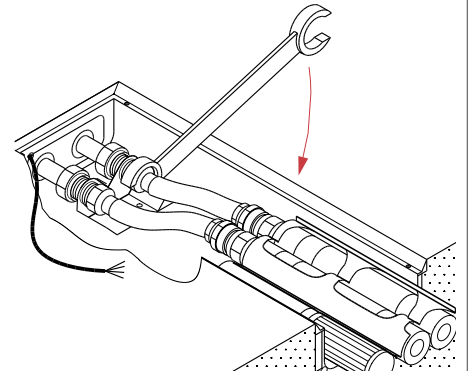

Checking the joints 1/1

After tightening, pressurise the system and check for possible leaks.

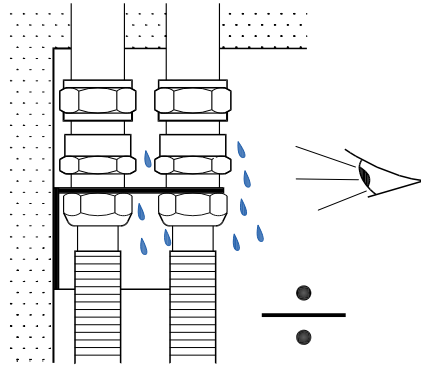

Power connection 1/2

Connect cables from the CHR room thermostat (or BMS system) and from the 24 V power supply.

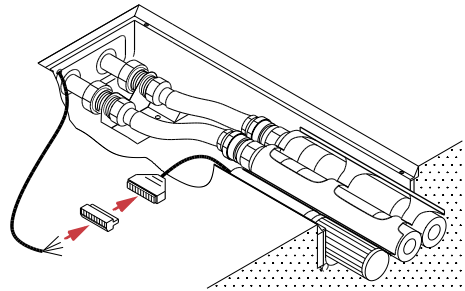

Power connection 2/2

Wiring must be carried out according to the electrical curcuit diagrams on page 13-14.

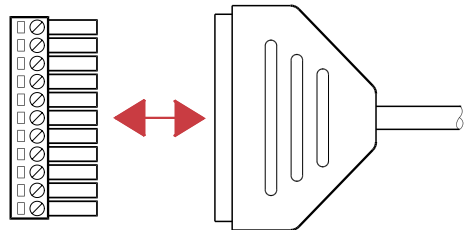

Adjusting the panel 1/2

Adapt the panel to the floor height using the integrated adjusting screws located at suitable intervals along the full length of the panel.

Use a 2.5 mm Allen key.

NB! On account of the panel's load strength, it is important for all adjusting screws to be adjusted correctly.

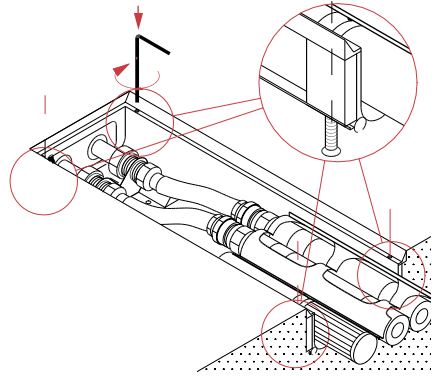

Adjusting the panel 2/2

Put the floor grating in place and check that it is aligned with the floor surface.

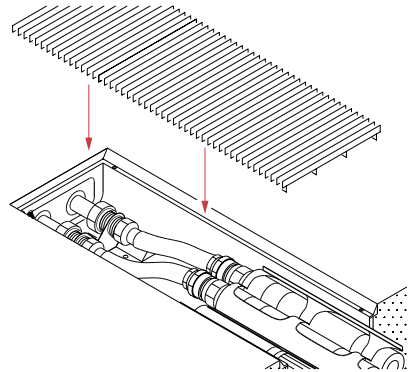

Opening the guide profile 1/4

Remove the floor grating from the panel.

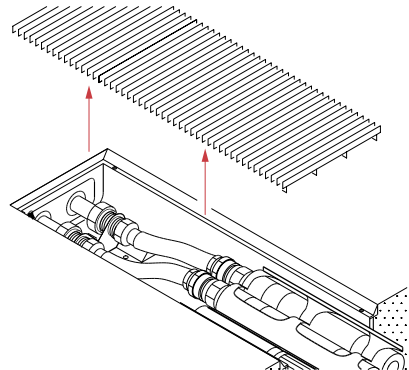

Opening the guide profile 2/4

Release the guide profile from the pipe fixture by pulling slightly.

Repeat this along the full length of the panel.

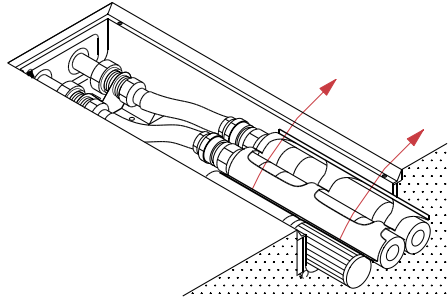

Opening the guide profile 3/4

The guide profile can now be lifted to give access to the base of the panel.

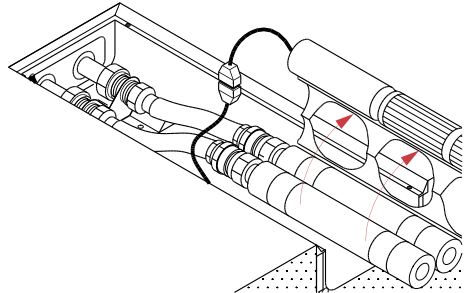

Opening the guide profile 4/4

When the guide profile is closed, secure it with light pressure on the Velcro pads.

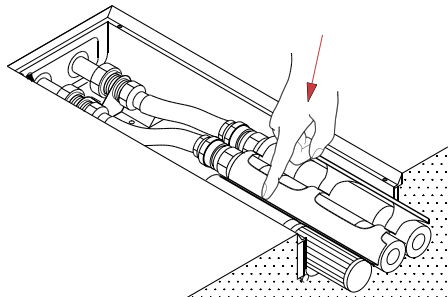

**Connecting several panels
in series 1/5**

Push the panels together.
The joint blocks (A) ensure precise panel
jointing.

Extend the flexible pipes to reach the fittings
on the next panel.

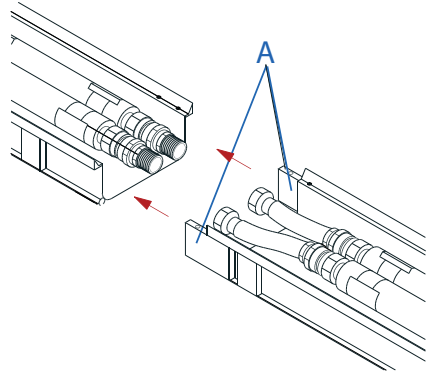

**Connecting several panels
in series 2/5**

To give room for thermal expansion, pull the
panels 2 mm apart.

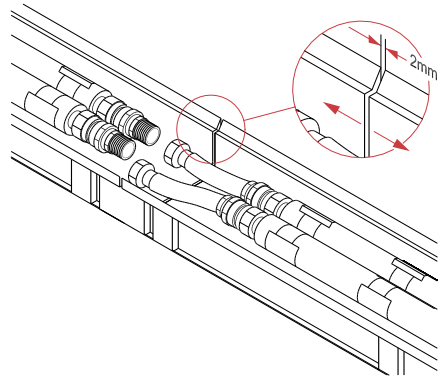

**Connecting several panels
in series 3/5**

Insert gaskets between the flexible pipes
and the fittings before fastening.

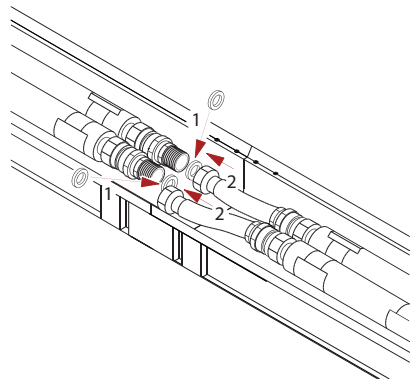

**Connecting several panels
in series 4/5**

Tighten the flexible pipes with an NV24 ring
spanner.

NB! Always hold the pipe in place in the
panel with multigrip pliers.

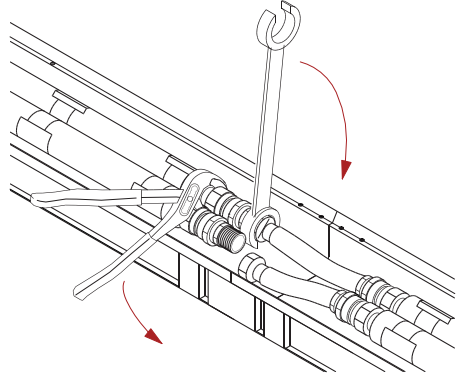

**Connecting several panels
in series 5/5**

After tightening, pressurise the system and
check for leaks.

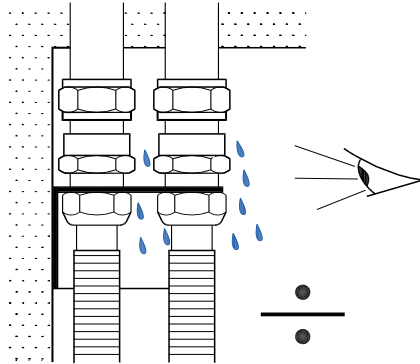

System with CHR room thermostat

A CHR can control up to 10 Convec panels in the same room.
 A Convec panel can be supplied with a valve to control flow through the panel.

NB! CHR room thermostats and CHM motor control have a common "0".

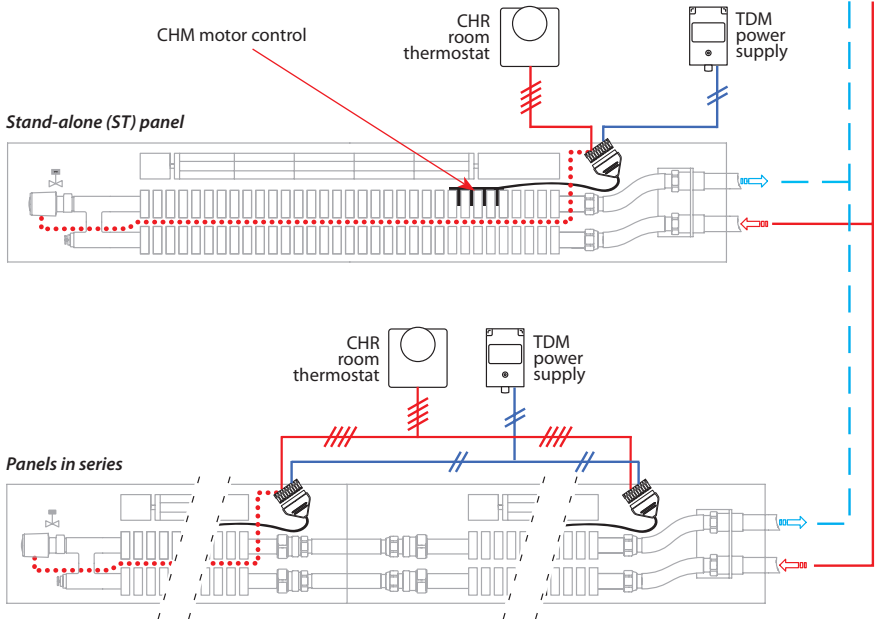

Wiring

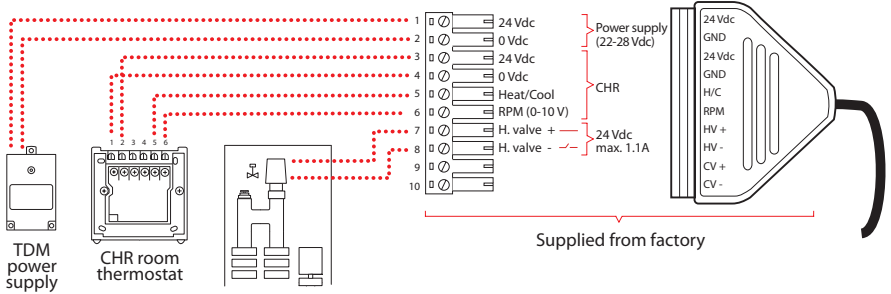

System with BMS control

A Convec panel can be controlled directly from a BMS system by a 0-10 V signal. Control of min. and max. fan speed is performed by the BMS system. However, the CHM motor control will continue to

perform the panel control, e.g. stopping the motor if blocked or the control of any decentralized valves. **NB!** Water supply valves are connected to cooling outputs 9 and 10.

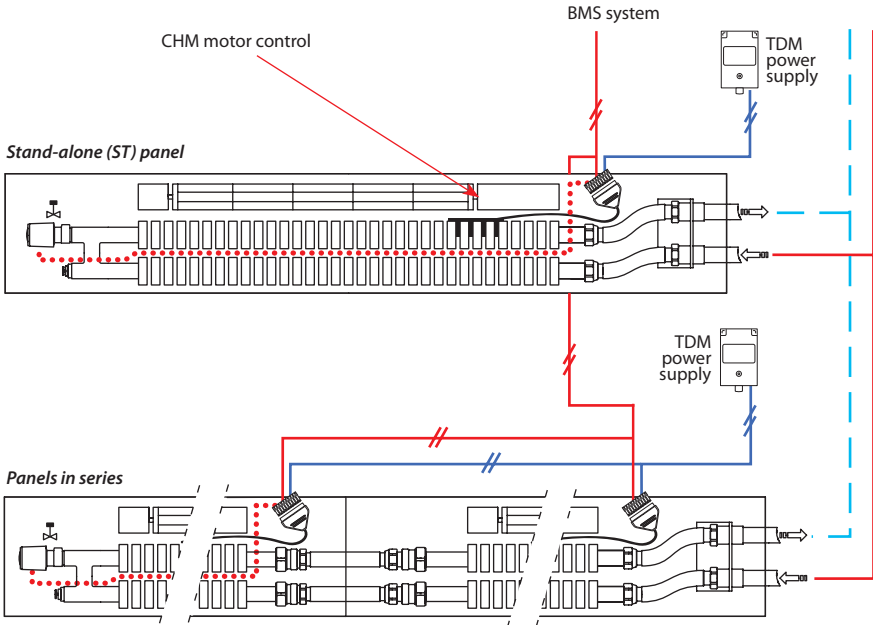

Wiring

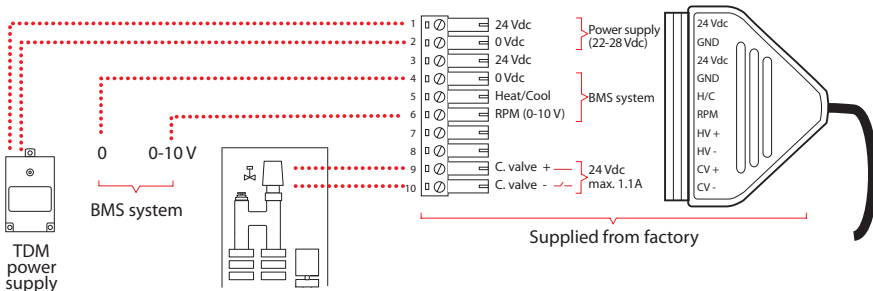

Operating conditions

Operating pressure 10 bar

Test pressure 13 bar

Storage temperature -10 - 60 °C

Water temperature 8 - 85 °C

Water quality VDI 2035

For further information please
contact:

MEINERTZ A/S
Sverigesvej 16
DK-8700 Horsens
Phone +45 8652 1811 Fax
+45 8652 1515
www.meinertz.com